

## Problem 1 - Terms

Explain the following terms. Draw symbols for the components and find an example (e.g. from DigiKey or Mouser).

- 1) NPN transistor and its terminals (NPN-transistori ja sen navat)
- 2) PNP transistor and its terminals. How is it different from a NPN transistor?
- 3) Biasing (Biasointi)
- 4) Capacitive coupling (Kapasitiivinen kytkentä)
- 5) Emitter follower (Emitteriseuraaja). What is it used for?

## Problem 2 - Bipolar junction transistor (BJT)

What are the states of the transistors in the following circuits (cutoff, active, saturation)? Calculate the base and collector currents. Explain your reasoning. For the BJT:  $\beta = 200$ ,  $V_{BE} = 0.7$  V.

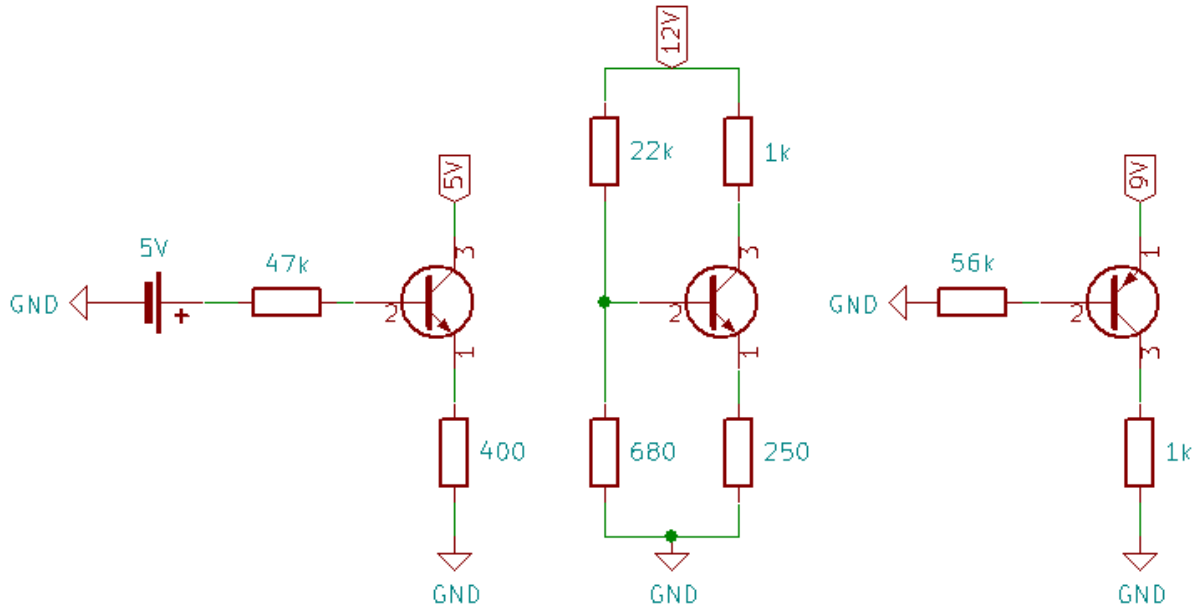

### Problem 3 - Some transistor circuits

- (a) What kind of component is the BSS138? Design a simple input circuit to produce at least 400 mA through the load R1. Use the ‘typical characteristics’ graphs in the datasheet. Can the transistor withstand the continuous current of that magnitude?
- (b) Design the input circuit for the NPN transistor to produce a 400 mA through R2, assume current gain of 200 and  $V_{BE} = 0.7$  V.

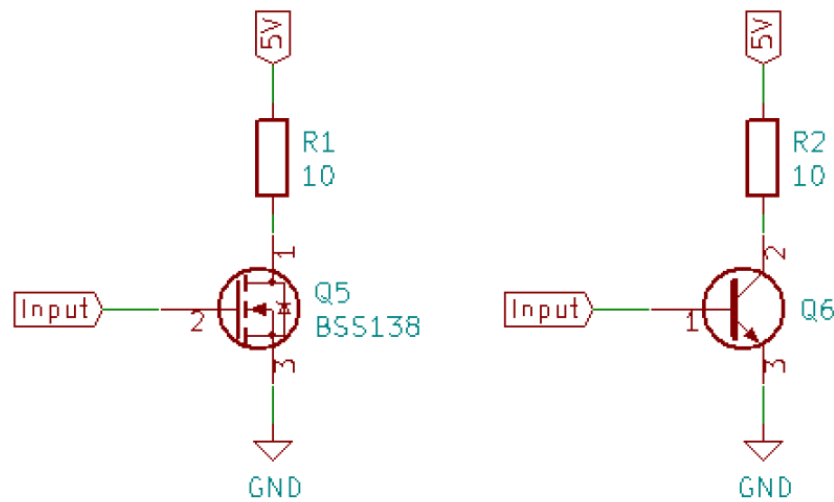

- (c) Now you control the FETs with an Arduino microcontroller connected to the input. An Arduino can produce voltages between 0 V and 5 V. Can you switch the light on/off?

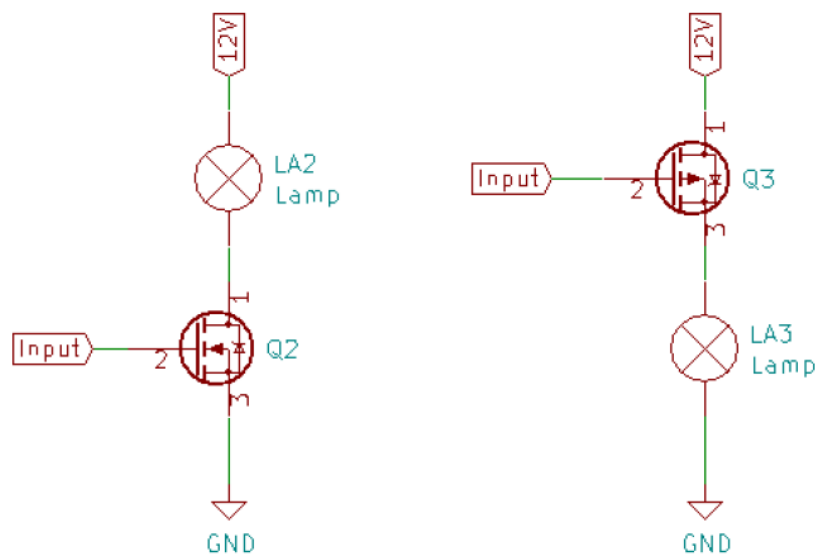

## Problem 4 - Simulate a common emitter amplifier

Simulate this common emitter amplifier. Connect C3 only in the b)-part.

- Connect a 0.2 V amplitude, 1 kHz sine at the input. What happens if you modify the value of R3? How about if you change the bias voltage (set by voltage divider R1 & R2)?
- Do an AC sweep from 10 Hz to 100 kHz. Compare the Bode plot with and without C3. What causes the difference?

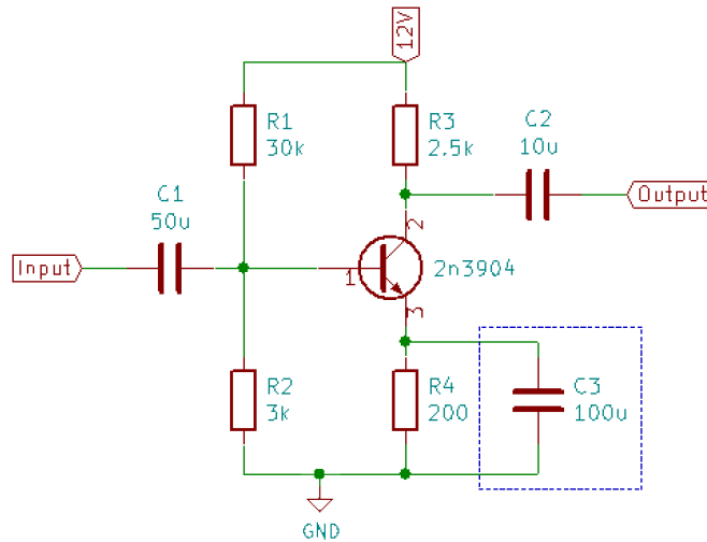

These tasks are done at the exercise sessions using the following equipment.

- Device: ADALM2000, a signal generator / oscilloscope combo device ([link](#)).
- Software: Scopy, which is used to control ADALM2000 ([link](#)).  
A guide to use each of the Scopy instruments is on bottom of the webpage.
- Various electronics components.

The course assistants will guide you.

**Please read the tutorial before the exercise session:** [A BJT Curve Tracer](#)

## Hands on task 3.1

Measure the characteristic curves of the transistors i.e. measure how the base current affects the collector current of NPN and PNP transistors. Alter the collector voltage. Experiment how FETs work.

## Hands on task 3.2

Build a common emitter amplifier using a transistor, resistors and trimmers. Try adjusting the trimmer. How does the operation of the amplifier change?