

Problem 1 - Term explanation

Explain the following terms. Draw symbols for the components and find an example (e.g. from DigiKey or Mouser).

- 1) N- and P-type Field Effect Transistor, FET (N- ja P-tyypin kanavatransistori)
- 2) Difference between BJTs and FETs?
- 3) Assumptions of the ideal op-amp model
- 4) Virtual ground (Virtuaalimaa)
- 5) Gain-bandwidth product GBWP (Taajuuskaistatulo)

Problem 2 - Op-amp basics

- (a) Calculate the output voltage as a function of the input voltage for the two op-amp circuits below. You can assume an ideal op-amp and ideal supply voltages (not shown in the circuit diagrams).

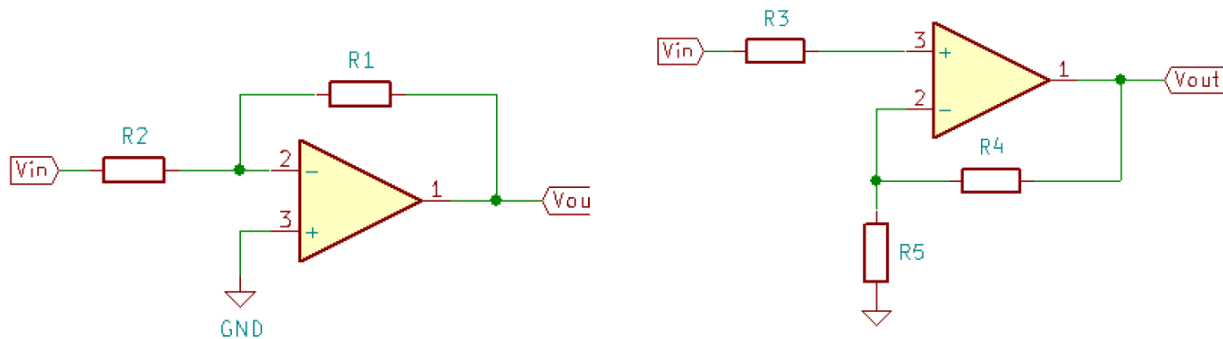

- (b) Here is an op-amp symbol with the supply voltages visible. Let's consider again the circuits above, but with $V_{S+} = 5\text{ V}$ and $V_{S-} = 0\text{ V}$. In case of an ideal op-amp, what would the output voltages limits be? What about for a real op-amp?
 Hint: Look for "Output voltage swing" in a datasheet (e.g. LM324).

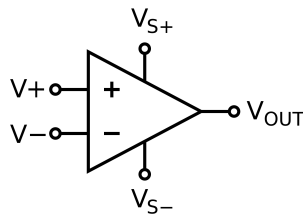

Problem 3 - More op-amp circuits

What is the output voltage as a function of the input voltage for the op-amp circuits below? What operation do these amplifier circuits do?

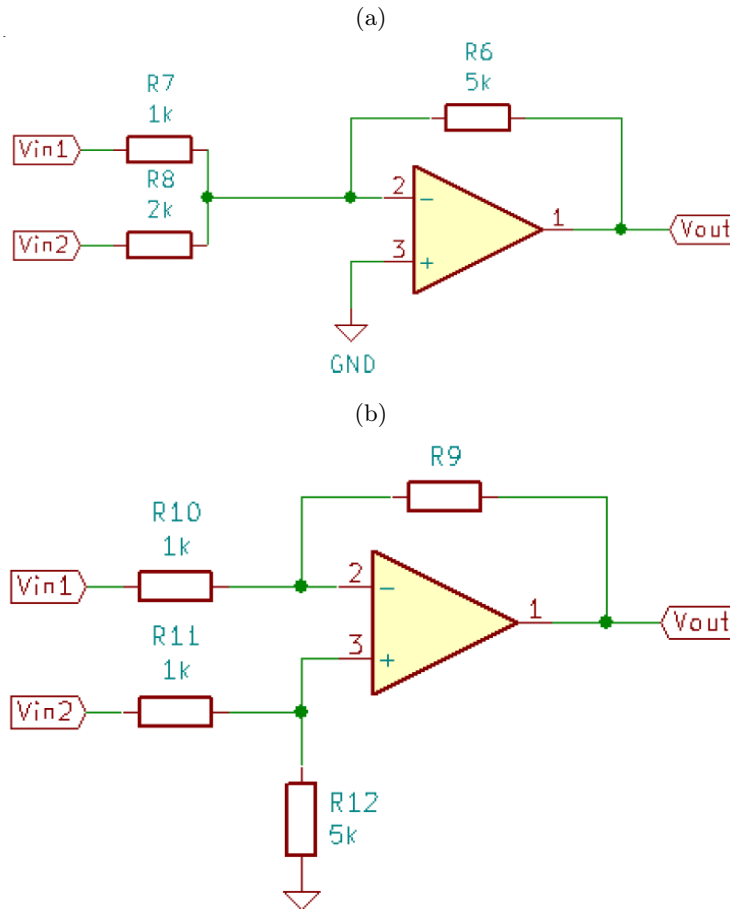

Problem 4 - Simulate an op-amp amplifier circuit

Simulate the amplifier circuit below. Use the ADA4000 which is one of the default components in LTspice. Determine the gain bandwidth product of the amplifier. What happens to the bandwidth of the amplifier if you increase the gain to 200? What operation does the circuit do when C1 is connected? Also, find out the required supply voltage and output power from the datasheet of the component.

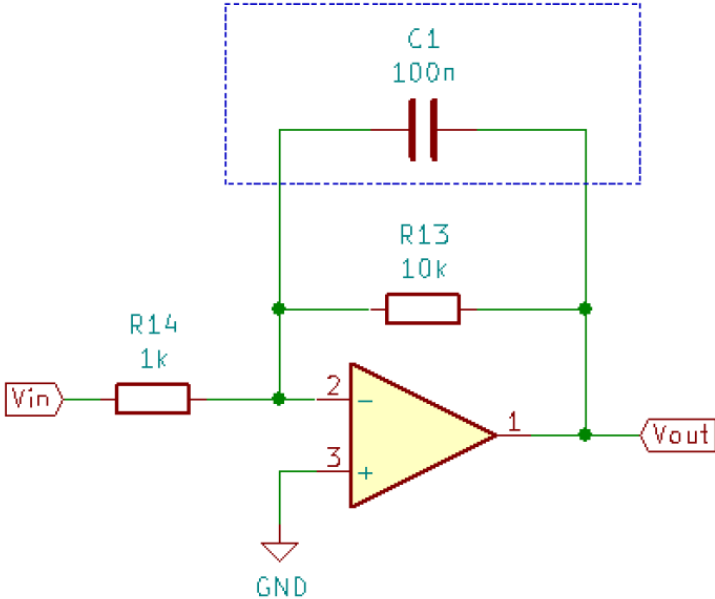

These tasks are done at the exercise sessions using the following equipment.

- Device: ADALM2000, a signal generator / oscilloscope combo device ([link](#)).
- Software: Scopy, which is used to control ADALM2000 ([link](#)).
A guide to use each of the Scopy instruments is on bottom of the webpage.
- Various electronics components.

The course assistants will guide you.

These resources can be of help when read beforehand:

- [Op-Amp basics](#)
- [ADALM2000 Simple Op Amps](#)

Hands on task 4.1

Create a simple inverting operational amplifier circuit. Test what happens to the output if you detach the feedback resistor or if you create a positive feedback?

Hands on task 4.2

Use the circuit as an audio amplifier. Attach a microphone to the input and a buzzer to the output.